

effenco 



HEAD™
Hybrid System

effenco 

HEAD™ HYBRID SYSTEM

Hydraulic
Equipment
Assisting
Device

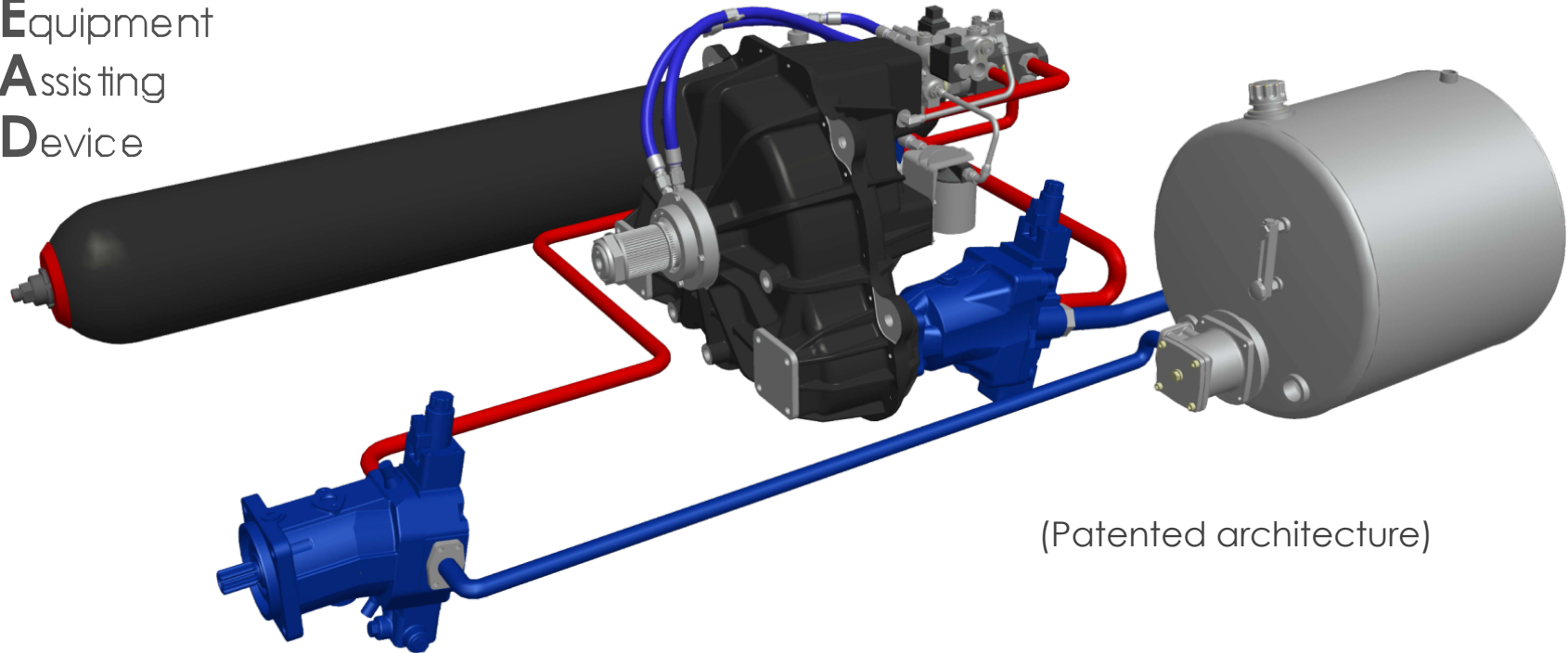

(Patented architecture)

An efficient, robust and simple Hydraulic Hybrid System based on a unique architecture specifically developed for refuse trucks

HOW IT WORKS

More details at:
www.effenco.com

For a preview of the system's operation, visit

www.effenco.com/en/products/video.html

- During braking, hydraulic pumps are used to slow down the vehicle, recovering kinetic energy that would be otherwise lost in heat.
- The recovered energy is stored in a hydraulic accumulator in the form of a pressurized fluid.
- The HEAD™ system uses the stored energy to assist the engine when it is the least efficient: at idle while driving auxiliary equipment (compactor, automated arm, etc.)

SYSTEM BENEFITS



Economics:

- **15 to 25 %** reduction in fuel consumption
- Increases brake life by a factor of **3**
- Operating costs reduced up to **15 000\$ every year**
- Reduces the impact of fuel price variations



Environment:

- Reduces green house gas emissions by up to **28 tons** per year (equivalent to **6 cars off the road**)
- Cuts emissions of NO_x, Particulates and SO₂ by 20%



Natural Gas trucks:

- **Extends range** of vehicles equipped with **CNG/LNG** engine

SYSTEM FEATURES



Modular:

- The HEAD™ system can be installed or **retrofitted** on any chassis

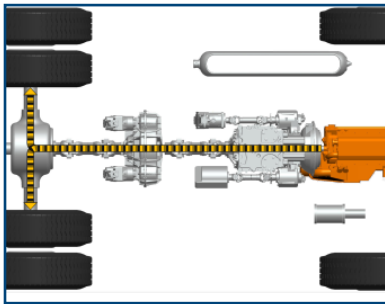

Parallel configuration:

- The HEAD™ system does not affect the truck's reliability due to its parallel configuration



Simple installation:

- Can be installed by any heavy-duty truck garage with basic equipment

SYSTEM FEATURES



Seamless:

- Operation of the regenerative braking is totally integrated within the conventional braking system



Interactive:

- Onboard dynamic driving guidance interface that gives feedback to the operator about his driving efficiency

Robust:

- Built from top of the line components:
Bosch Rexroth – Hydac – Chelsea

Rexroth
Bosch Group

HYDAC

Parker | Chelsea

effenco 